

Intelligent Drivesystems, Worldwide Services



GB

**Control cabinet inverter**

**SK 500E 0.25 to 160 kW**

Product overview

  
**DRIVESYSTEMS**

# One for all

## The SK 500E product family



### Safety

The SK 500E includes a comprehensive safety concept for all drive components

#### Motor, Gear Unit and Application

- Thermal motor protection TF (PTC), I<sup>2</sup>t
- Short-circuit / Earth fault monitoring
- Phase error and flux monitoring
- Speed, direction and slip monitoring with encoder feedback
- Load monitoring and limitation
- Error management with saving of faults and their contexts, error statistics



#### Frequency inverters

- Temperature monitoring
- Short circuit / Earth fault / Current monitoring
- Overvoltage / Undervoltage and phase monitoring

#### Peripherals

- Communication monitoring with integrated watchdogs
- Parameterised inputs for evaluation of sensor signals

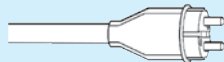

#### Environment

- RoHS compliant
- High EMC protection through integrated line filter (C1 up to 5 m cable length for devices up to 7.5 kW, C2 up to 20 m cable length, screened cable)

#### Reliable operation through genuine large overload reserves

- 200 % rated load, 3.5 s / 150 % rated load, 60 s

The SK 500E inverter range from NORD Drivesystems is available for motors with rated powers from 0.25 - 132 kW (160 kW from the middle of 2014). Due to its very compact design it is ideally suitable for space-saving installation in control cabinets.

Features such as:

- sensorless current vector control, which provides constant speed with fluctuating loads and very high starting torques,
- 200% overload reserve, which ensures greater safety for crane and lifting gear applications,
- an integrated brake chopper for 4-quadrant operation,
- an integrated line filter as the basis for optimum EMC performance

are included in the basic equipment of the entire range, as well as a PID or process controller. These controllers automatically control your application.

There is a choice of devices with an integrated 24 V mains unit or a separate connection for the control board supply. Devices with an external supply have the advantage that even when they are

switched off, the parameter data can be accessed and communication is possible via bus interfaces. In addition, such an inverter enables self-controlled evacuation runs, which is an enormous safety benefit, not just for lifting gear drives.

The SK 51xE and SK 53xE models support the "Safe Stop" function according to EN 13849-1 (up to the maximum safety category 4, stop categories 0 and 1), whereby the SK 53xE version with its built-in POSICON function is ideally equipped for all positioning tasks (relative and absolute). The top model SK 540E /SK 545E supports convenient free programming functions close to the drive unit in accordance with IEC 61131 and also enables the operation of synchronous motors with permanent magnet excitation. Even with their various functions the inverters have the same physical dimensions.

Equipment	Page 3
Software	Page 10
Overview of devices	Page 12
Control connections	Page 13
Accessories	Page 14
Technical data	Page 32





- **Sensorless current vector control** (ISD control) for high precision control and fast response times
- **Brake management**, electromagnetic holding brake
- **Brake chopper** to divert generated energy to a brake resistor
- **RS 232 PC diagnostic interface**
- **4 switchable parameter sets** for the flexible use of parameter settings (e.g. switchover between drives with different motor data)
- **All common drive functions**  
e.g. acceleration / braking on a ramp
- **Parameters are set with** default values so that they can be used immediately
- **Scaleable display values**
- **Stator resistance measurement** to ensure optimum control characteristics



#### Optional

- Interfaces for many bus systems
- Various control options (switches, potentiometers or ParameterBoxes)
- Versions with functional safety (Safe Stop) [SK 510E and above]
- Versions with incremental encoder interface for speed feedback (servo mode) [SK 520E and above]
- POSICON version with positioning function (relative and absolute) [SK 530E and higher]
- Versions with PLC functionality and universal encoder interface [SK 540E and higher]

### Energy saving function

- Ultimate efficiency in partial load operation
- Reduced operating costs through energy savings of up to 60 %
- Simple setting via parameters



### User friendly

- Easy adaptation to communication systems through plug-in technology units.
- Quick and simple diagnosis with easily visible LED indicators.
- Technology units available for display, operation and parameterisation
  - Easy to read large LCD display in 14 languages (optional).
  - Simple operation and parameterisation thanks to logical parameter structure and intuitive layout of control elements.
  - Versions for control cabinet installation

# Inner values matter

## Extensive basic equipment

### Load monitor

- **Monitoring** of load torque depending on the output frequency
- **Individual** adaptation of load monitoring to protect the system from overload in particular frequency ranges

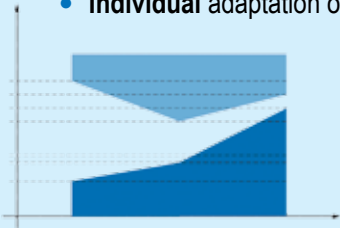

### Link circuit coupling

Intermediate circuit via terminals for all versions

- **Energy saving effect** with balanced motor and generator operation
- **Elimination** of brake resistors possible

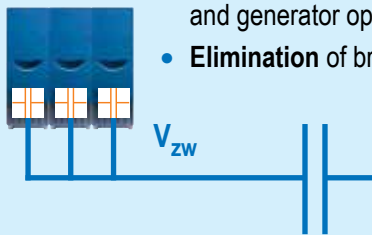

### Lifting gear functions

- High precision current vector control for **rapid** and **precise** load take-up
- **Integrated brake chopper** to divert generated energy to a brake resistor (optional)
- Brake management for **optimum control** of an electromagnetic holding brake for **wear-free** actuation of the brake

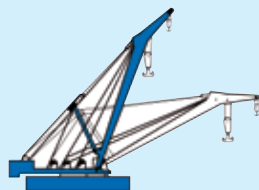

### Process controller, PID controller

- Feedback and evaluation of actual values for the implementation of a **closed control loop** (e.g. flux, compensator control)
- P, I and D component can be set separately

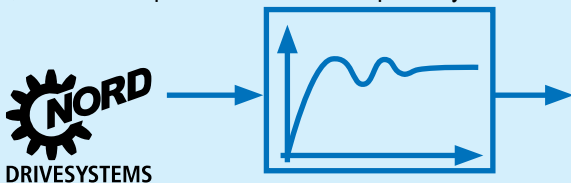



### Servo mode

- **High precision** speed control
- **Highest possible** acceleration through direct feedback of the actual speed to the frequency inverter and therefore:
  - **Full torque** down to standstill (speed 0)
  - Digital speed controller with **wide range of settings**

Available with SK 520E or higher



### Evacuation runs

- Evacuation run possible if the main supply fails
- **Emergency operation** with low DC voltage from external power supply (e.g. battery) possible

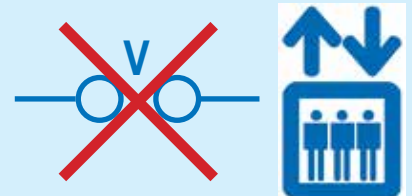

Available for all SK 5x5E devices

### Master / Slave operation

- **Control** of one or more slave inverters by a master inverter
- **Communication** via USS or CANopen with control words and setpoint values
- Speed or **synchronised** positioning possible according to performance level

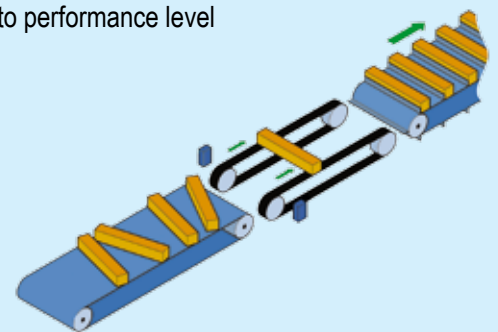

# In case of emergency

## Safe Stop STO and SS1

Personnel safety and high machine availability are the focus in system operations. After a safety circuit is actuated by opening a safety cover or door, it must be ensured that no rotating system components can lead to accidents at work.

For a motor which is operated with a NORD frequency inverter, this is triggered by a safe pulse block which offers protection against the motor restarting according to the applicable standards.

This safe block includes voltage supply to the circuit breaker by means of a safety switching device. The frequency inverter is therefore immediately ready to be switched on without re-initialisation after the safety circuit is closed.

### Safe Stop Standards

- DIN EN ISO 13849-1: Performance Level e
- DIN EN 61508: SIL 3
- DIN EN 60204-1: Stop function
- DIN EN 61800-5-2: Safety functions

### Applications

- Rotating machine tools (e.g. milling machines)
- Closed moving systems with safety doors

### Advantages at a glance

- Certified by TÜV NORD
- Safely switched off torque (STO)
- Safe Stop 1 (SS1)
- High machine availability through continuous online operation
- Elimination of protective components
- No initialisation delays
- Long service life due to electronic switching (no electromechanical contacts)
- Low cost solution with compact device

Available for SK 510E and above, except fro SK 520E

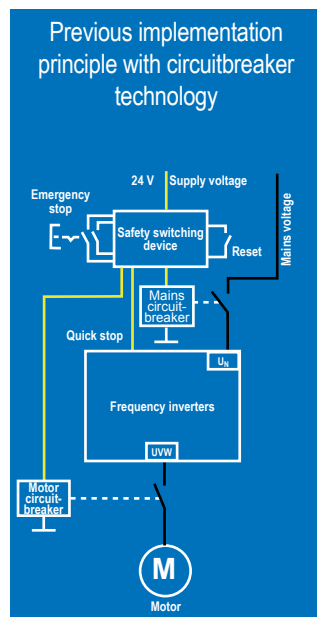
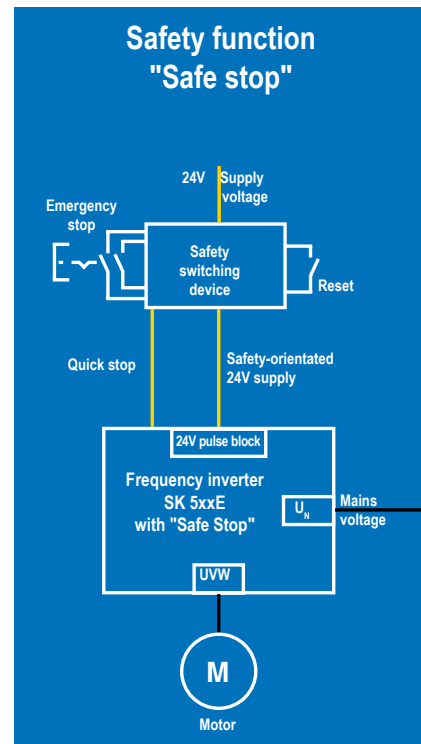

# Precision and logic

## POSION and PLC

### POSION

Frequency inverters with integrated POSICON functionality are able to determine the actual position of the drive unit via appropriate interfaces. Incremental encoder inputs (TTL / HTL) or absolute encoders are available as interfaces via CANopen (from SK 540E and above sine wave encoders, SSI, BISS, EnDat 2.1 and Hiperface are also available). In addition to conventional point-to-point positioning (absolute positioning), POSICON also provides the facility for relative positioning of endless axes as well as various technology functions (rotating platform "with travel optimisation", synchronous operation and flying saw).

By means of the standard position POSICON position memory and features such as "teach in", "reference point run", "reset position", "offset position", "target window positioning" and "S-ramp", the frequency inverter is able to perform a complete, independent positioning control. The tasks for the external control are therefore reduced to the starting pulse and communication of the target position (via digital I/O or at the field bus level). The frequency inverter can even undertake monitoring of the positioning process and reporting of the operating status.

#### Applications

- Lifting gear / storage and retrieval devices with precise position control
- Bridge trolleys for material handling systems / portal cranes with synchronisation function for all driven axes
- Rotating platform functions for tool magazines on machine tools
- Flying saw: Control and parallel guidance of a saw on a moving object

**Available for SK 530E and above**

### PLC

In most cases the frequency inverter is controlled by means of an overriding PLC. However, the use of an external PLC requires additional space and installation expense in order to implement communication between the PLC and the participants (e.g. frequency inverters). In many systems with relatively simple drive functions, the expense required soon becomes unacceptable.

This is where the SK 540E / SK 545E come into their own. Their integrated Instruction List (IL) based PLC functionality (based on IEC 61131-3) is specially designed for drive functions. With a computational performance of approx. 200 IL commands per millisecond and a total of 1280 commands in the program, this control unit is able to undertake many tasks in the field of the frequency inverter. Inverter inputs or information from a connected field bus can be monitored, evaluated and further processed into appropriate setpoint values for the frequency inverter. Visualisation of system statuses and the input of special customer parameters is possible by means of optional equipment (ParameterBox, NORDCON software).

#### Applications

- Control / regulation of one or more devices by the inverter

**Available for SK 540E and above**

# Versatile and sustainable

## Frequency inverters with servo operation



### Universal encoder interface

The universal encoder interface enables the connection of most common encoder systems to the frequency inverter. This absolute encoder interface is especially important for the operation of synchronous motors.

In addition to SSI encoders and BiSS encoders (a further development of the SSI encoder), EnDat encoders with profile 2.1 and Hiperface encoders can also be evaluated.

**Available for SK 540E and above**



### Synchronous motor operation (as energy-saving motor)

The SK 54xE provides synchronous technology in the standard NORD housing.

PMSM as energy-saving motor

- Optimal relationship between manufacturing costs and efficiency
- High energy-saving potential for pump and fan/blower applications
- Control without encoders

PMSM and ASM for sophisticated applications

- Single-axis applications with increased dynamics



**Available for SK 540E and above**





# Stay cool

## Alternative cooling systems

### Alternative cooling systems "Cold-Plate" and external heat sink technology

In the Cold-Plate version, the standard heat sink is replaced by a flat cooling flange. To transfer the heat from the inverter, the flange is mounted on a surface cooled by e.g. water, air or oil. Important advantages are the reduction in installation depth of the inverter by approx. 35 mm to 119 mm and improved heat dissipation. With the external heat sink technology, a ribbed heat sink is supplied as an optional module which is mounted on the Cold-Plate unit. The inverter is installed in the control cabinet with the heat sink located outside the cabinet so that a large part of the heat to be dissipated is transferred there. This reduces the internal temperature of the control cabinet, so that air conditioners and fans can be correspondingly smaller or omitted completely.

#### Optionally available:

**External heat sink technology: all devices up to Size 2, 2.2 kW**

**Cold-Plate technology: all devices up to Size 4, 7.5 kW**



Cold-Plate



External heat sink technology



### ATEX compliant drive systems for increased safety

Tested and certified combinations of SK 500E inverters and NORD motors with increased safety are available. Where in typical inverter operation, pressure-resistant encapsulated motors must be used, a combination of Exe motor and a NORD SK 500E frequency inverter\* can be employed. This results in a considerable cost saving. The weight and price of such a drive package is very competitive in relation to the motor performance and therefore offers an efficient solution.

\* Installation of the frequency inverter outside of the hazard area!

#### Advantages at a glance:

- Up to 40 % price advantage for the geared motor compared with pressure-resistant motors
- Significant weight reduction
- PTB acceptance for Zone 1 and Zone 2
- 50 Hz or 87 Hz characteristic curve possible
- Control range 5 Hz to 100 Hz
- Power range from 0.18 kW to 13.5 kW (motor power)

# Dialogue with specialists

## Free software for our electronics

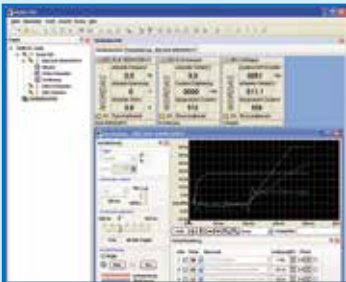
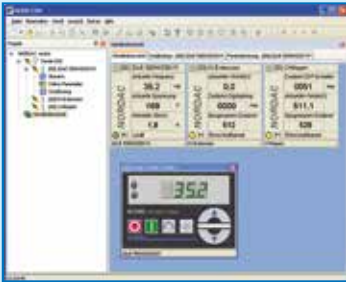

### NORDCON software

NORDCON is the free operating software for controlling, parameterisation and diagnostics of all NORD frequency inverters.

#### Remote control

A virtual control unit, analogous to a SimpleBox (optional control and parameterisation unit), enables the display of operating values, parameterisation and the control of a connected frequency inverter.

#### Parameterisation

By means of a convenient overview the user can view and adjust each available parameter. By means of an appropriate printing option, parameter lists are generated in printed form either completely or only with the values which deviate from the default settings. The finished data sets can be saved on a PC/laptop and archived for future use or sent by email.

#### Diagnosis

The NORDCON oscilloscope function is an extremely useful instrument for the optimum adjustment of drive systems. By means of line graphs, all drive characteristics (current, torque, etc.) can be recorded and analysed. On the basis of the results, fine tuning of the ideal parameter settings of the relevant drive unit is possible.

#### Programming of the PLC (SK 540E and above)

A PLC editor is available for creating, editing and managing PLC programs. The PLC programs can also be tested (debugged) with this editor and communicated to the frequency inverter.

# In use everywhere

## NORD drive technology in industry

**NORD** is represented in many branches of industry with its drives and control technology. According to the application, the required functions

range from simple speed control up to high-end functions with Safe Stop, flying saw and others.

### Sectors

### Applications

- Waste Water Technology
- Theatre technology
- Material Handling
- Airport Technology
- Steel industry
- Food Industry
- Cement industry
- Pump industry
- Mining and quarrying
- Building

- Fans  
Ventilators
- Small devices  
Pumps  
Cooling circuits
- Bucket conveyors
- Lifting gear  
Cranes
- Elevators  
RGBs
- Conveyor belts  
Material handling
- Portal cranes  
Bridge trolleys
- Bottling systems
- Tool magazines  
Distribution systems  
Sorting systems
- Crushers  
Mixers  
Shredders

# The whole team

## All device versions at a glance

		SK 500E	SK 505E	SK 510E	SK 511E	SK 515E	SK 520E	SK 530E	SK 535E	SK 540E	SK 545E	SK 515E	SK 535E	SK 545E
		Size 1-4										Size 5-11		
Basic functions	Sensorless current vector control (ISD control)	✓	✓	✓	✓	✓	✓	✓	✓	✓	✓	✓	✓	✓
	Brake management for mechanical holding brake	✓	✓	✓	✓	✓	✓	✓	✓	✓	✓	✓	✓	✓
	Brake chopper (Brake resistor optional)	✓	✓	✓	✓	✓	✓	✓	✓	✓	✓	✓	✓	✓
	RS 232 PC diagnostic interface	✓	✓	✓	✓	✓	✓	✓	✓	✓	✓	✓	✓	✓
	4 switchable parameter sets	✓	✓	✓	✓	✓	✓	✓	✓	✓	✓	✓	✓	✓
	All normal drive functions	✓	✓	✓	✓	✓	✓	✓	✓	✓	✓	✓	✓	✓
	Parameters pre-set with standard values	✓	✓	✓	✓	✓	✓	✓	✓	✓	✓	✓	✓	✓
	Scaleable display values	✓	✓	✓	✓	✓	✓	✓	✓	✓	✓	✓	✓	✓
	Stator resistance measurement	✓	✓	✓	✓	✓	✓	✓	✓	✓	✓	✓	✓	✓
	Automatic flux optimisation (energy saving function).	✓	✓	✓	✓	✓	✓	✓	✓	✓	✓	✓	✓	✓
	Line filter Class C2, up to 5 m motor cable Class C1 up to size 4	✓	✓	✓	✓	✓	✓	✓	✓	✓	✓	✓	✓	✓
	Monitoring functions	✓	✓	✓	✓	✓	✓	✓	✓	✓	✓	✓	✓	✓
	Load monitor	✓	✓	✓	✓	✓	✓	✓	✓	✓	✓	✓	✓	✓
	Link circuit coupling	✓	✓	✓	✓	✓	✓	✓	✓	✓	✓	✓	✓	✓
	Lifting gear functionality	✓	✓	✓	✓	✓	✓	✓	✓	✓	✓	✓	✓	✓
Process controller / PID controller	✓	✓	✓	✓	✓	✓	✓	✓	✓	✓	✓	✓	✓	
Options	Coldplate up to Size 4, external heat sink technology up to Size 2	○	○	○	○	○	○	○	○	○	○			
	All common field bus systems	○	○	○	○	○	○	○	○	○	○	○	○	○
	"Safe Stop" function			✓	✓	✓		✓	✓	✓	✓	✓	✓	✓
	CANopen on Board				✓		✓	✓	✓	✓	✓	✓	✓	✓
	Evacuation runs		✓			✓			✓		✓	✓	✓	✓
	Incremental encoder input (servo mode)						✓	✓	✓	✓	✓		✓	✓
	POSICON							✓	✓	✓	✓		✓	✓
	Internal 24 V mains unit for control board power supply	✓		✓	✓		✓	✓		✓		✓	✓	✓
	External 24 V power supply for control board		✓			✓			✓		✓	✓	✓	✓
	PLC logic function									✓	✓			✓
	Universal encoder interface									✓	✓			✓
Synchronous motor operation (PMSM)									✓	✓			✓	

○ Optional module / Version



# The Senses

## Control connections to the frequency inverter

		SK 500E	SK 505E	SK 510E	SK 511E	SK 515E	SK 520E	SK 530E	SK 535E	SK 540E	SK 545E	SK 515E	SK 535E	SK 545E
		Size 1-4										Size 5-11		
Control terminals	DIN	5	5	5	5	5	7	7	7	6-8 <sup>1</sup>	6-8 <sup>1</sup>	5	7	6-8 <sup>1</sup>
	DOUT	0	0	0	0	0	2	2	2	3-1 <sup>1</sup>	3-1 <sup>1</sup>	0	2	3-1 <sup>1</sup>
	Signal relay <sup>2</sup> (... 230VAC, 2A)	2	2	2	2	2	2	2	2	2	2	2	2	2
	AIN <sup>3</sup>	2	2	2	2	2	2	2	2	2	2	2	2	2
	AOUT <sup>3</sup>	1	1	1	1	1	1	1	1	1	1	1	1	1
	TF (PTC)	1 <sup>4</sup>	1 <sup>4</sup>	1 <sup>4</sup>	1 <sup>4</sup>	1 <sup>4</sup>	1 <sup>4</sup>	1 <sup>4</sup>	1 <sup>4</sup>	1 <sup>4</sup>	1	1	1	1
Encoder interfaces	TTL RS422						✓	✓	✓	✓	✓		✓	✓
	HTL <sup>4</sup>						✓	✓	✓	✓	✓		✓	✓
	SIN / COS									✓	✓			✓
	SSI									✓	✓			✓
	BISS									✓	✓			✓
	Hiperface									✓	✓			✓
	Endat 2.1									✓	✓			✓
	CANopen							✓	✓	✓	✓		✓	✓
Communication	CAN /CANopen RJ45				2		2	2	2	2	2	2	2	2
	RS 485 / RS232 RJ12	1	1	1	1	1	1	1	1	1	1	1	1	1
	RS 485 Terminal connection						1	1	1	1	1		1	1
	Modbus RTU									✓	✓			✓

<sup>1</sup> 2 Digital IOs can be optionally parameterised as DIN or DOUT

<sup>2</sup> Can be parameterised with DOUT functions

<sup>3</sup> AIN / AOUT can also be used for digital signals.

AIN: 0(2) – 10 V, 0(4) – 20 mA, only SK 54xE: additionally ± 10 V

<sup>4</sup> Function can be parameterised via a digital input

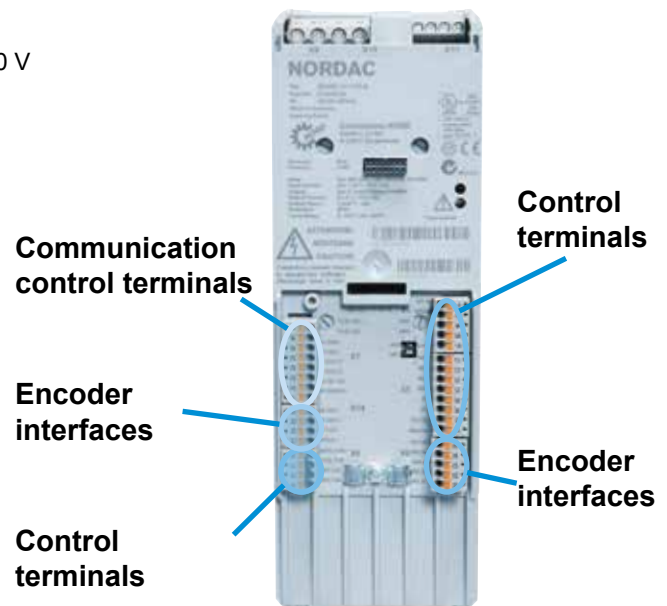

# Do you need anything else?

## EMC Kit

For EMC-compliant connection of a shielded cable and as a strain relief.



Size of the frequency inverter	EMC Kit	Part Number
Size 1 and Size 2	SK EMC 2-1	275 999 011
Size 3 and Size 4	SK EMC 2-2	275 999 021
Size 5	SK EMC 2-3	275 999 031
Size 6	SK EMC 2-4	275 999 041
Size 7	SK EMC 2-5	275 999 051
Size 8 and Size 9	SK EMC 2-6	275 999 061
Size 10 and Size 11	SK EMC 2-7	275 999 071

## Connection kit

### HTL encoder WK 4/2/4\*680 OHM

For connection of an HTL encoder to the TTL encoder input of the frequency inverter, snap-on mounting.

Part No. 278 910 340



## Setpoint converter +/- 10V

For connection of a bipolar analog signal to the unipolar input of a frequency inverter (up to Size 4), Snap-on mounting.

Part. No.: 278,910,320





Each frequency inverter is equipped with a slot for installing a type SK TU3- technology unit.

Either control and parameterisation modules or interfaces from field bus systems can be selected.



Installation of the modules is quick and simple.



## Display and control

Optional modules with up to 14 languages for the display of status and operating messages, parameterisation and operation of the frequency inverter. Handheld versions are also available in addition to versions for direct mounting on the device or for installations in a control cabinet door.



## Interfaces for field bus systems

Integration of the frequency inverter into a field bus system (conventional or Ethernet-based) is via an appropriate interface in the form of a type SK TU3-... technology unit. This is installed directly into the technology unit slot on the device.



## IO expansion module SK EBIOE-2

The wide range of standard inputs and outputs on the device can be supplemented with an extension which is mounted on a snap-on rail. Part No.: 275 900 210

**Available for SK 540E and above**



## Electronic brake rectifier SK EBGR-1

For direct control and activation of an electromechanical holding brake. Part No.: 19 140 990

**Available for SK 540E and above**

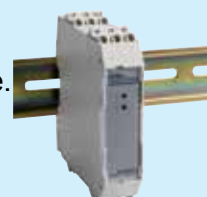

# Technology Units

## Operation and parameterisation

### ControlBoxes

Module	Designation	Description	Data	Part No.
SK CSX-0	SimpleBox	Commissioning, parameterisation and control of the frequency inverter	7 segment, 4-digit LED display, single button operation	275 900 095
SK CSX - 3E	SimpleControlBox	As for SK CSX-0 + Saving of parameters for one inverter + Installation version for control cabinet (doors) IP54	7-segment, 4-digit, LED display, keyboard	275 281 413
SK PAR - 3E	ParameterBox	As for SK CSX-0 + Saving of parameters for up to 5 inverters + Plain language in 14 languages + Installation version for control cabinet (doors) IP54	LCD display (illuminated) 4 line, keyboard	275 281 414
SK TU3-CTR	ControlBox	As for SK CSX-0 + Saving of parameters for one inverter	7-segment, 4-digit, LED display, keyboard	275 900 090
SK TU3-PAR	ParameterBox	As for SK CSX-0 + Saving of parameters for up to 5 inverters + Plain language in 14 languages	LCD display (illuminated) 4 line, keyboard	275 900 100
SK TU3-POT	PotentiometerBox	Direct control of the FI	ON, OFF, R/L, 0...100 %	275 900 110



**SK CSX-0**



**SK CSX - 3E**



**SK PAR - 3E**



**SK TU3-PAR**



**SK TU3-CTR**



**SK TU3-POT**



# Technology Units

## BUS / Communication

### Conventional field bus protocols

Module	Designation	Description	Part No.
SK TU3-AS1	AS Interface	4 sensors / 2 actuators 5 and 8 pole screw terminals	275 900 170
SK TU3-CAO	CANopen	Baud rate: up to 1 MBit/s Connector: Sub-D9	275 900 075
SK TU3-DEV	DeviceNet	Baud rate: 500 KBit/s 5-pole screw terminal	275 900 085
SK TU3-IBS	InterBus	Baud rate: 500 kBit/s (2Mbit/s) Connector: 2 x Sub-D9	275 900 065
SK TU3-PBR	Profibus DP	Baud rate: 1.5 Mbaud connector: Sub-D9	275 900 030
SK TU3-PBR-24V	Profibus DP	Baud rate: 12 Mbaud connector: Sub-D9 24 V connection via terminal	275 900 160

### Ethernet-based bus systems

Module	Designation	Description	Part No.
SK TU3-ECT	EtherCAT	Baud rate: 100 MBaud Connector: 2 x RJ45 24 V connection via terminal	275 900 180
SK TU3-EIP	Ethernet/IP	Baud rate: 100 MBaud Connector: 2 x RJ45 24 V connection via terminal	275 900 150
SK TU3-PNT	PROFINET IO	Baud rate: 100 MBaud Connector: 2 x RJ45 24 V connection via terminal	275 900 190
SK TU3-POL	POWERLINK	Baud rate: 100 MBaud Connector: 2 x RJ45 24 V connection via terminal	275 900 140

# Line filter

## General information

Line filters are generally used to reduce the emission of electromagnetic interference. SK 500E series frequency inverters are equipped with an integrated Class C2 line filter (max. 20 m shielded motor cable) of Class C1 (Size 1-4, max. 5 m shielded motor cable). Various adaptive line filters are available for longer cable lengths or to improve interference suppression.

## Chassis line filter, SK HLD (IP20)

The line filters are mounted separately from the frequency inverter. These line filters enable interference suppression Class C1 with max. 25 m shielded motor cable and Class C2 with max. 50 m cable.



## Chassis line filter

Inverter type SK 5xxE ...		Line filter type IP20	Part Number
3~ 230 V	0.25 ... 1.1 kW	SK HLD 110-500/8	278 272 008
	1.5 ... 2.2 kW	SK HLD 110-500/16	278 272 016
	3.0 ... 5.5 kW	SK HLD 110-500/30	278 272 030
	7.5 kW	SK HLD 110-500/42	278 272 042
	11 kW	SK HLD 110-500/75	278 272 075
	15 kW	SK HLD 110-500/100	278 272 100
3~ 400 V	0.55 ... 2.2 kW	SK HLD 110-500/8	278 272 008
	3.0 ... 5.5 kW	SK HLD 110-500/16	278 272 016
	7.5 kW	SK HLD 110-500/30	278 272 030
	11 kW	SK HLD 110-500/42	278 272 042
	15 ... 18.5 kW	SK HLD 110-500/55	278 272 055
	22 kW	SK HLD 110-500/75	278 272 075
	30 kW	SK HLD 110-500/100	278 272 100
	37 ... 45 kW	SK HLD 110-500/130	278 272 130
	55 kW	SK HLD 110-500/180	278 272 180
	75 ... 90 kW	SK HLD 110-500/250	278 272 250
	110 ... 160 kW	in preparation	

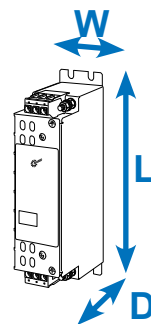

Continuous current [A]	Leakage current <sup>1</sup> [mA]	L [mm]	W [mm]	D [mm]
8	20 / 190	190	45	75
16	21 / 205	250	45	75
30	29 / 280	270	55	95
42	30 / 290	310	55	95
75	22 / 210	310	85	135
100	30 / 290	325	95	150
8	20 / 190	190	45	75
16	21 / 205	250	45	75
30	29 / 280	270	55	95
42	30 / 290	310	55	95
55	30 / 290	255	85	95
75	22 / 210	310	85	135
100	30 / 290	325	95	150
130	22 / 210	325	95	150
180	31 / 300	440	130	181
250	37 / 355	525	155	220

<sup>1</sup> Leakage current 1st value: rated according to max. permissible fluctuation of input voltage according to IEC 38 + 10 %  
 Leakage current 2nd value: calculated with max. input voltage and failure of 2 phases (typically at 50 Hz)

# Line filter

## Footprint line filters, combination filters SK NHD (IP20)

For frequency inverter powers of up to 7.5 kW (400 V) are available. The line filter can be mounted flat underneath the frequency inverter. This reduces the space which is required. These combination filters combine the advantages of a line filter and a line choke in a single housing and enable interference suppression Class C1 with max. 50 m shielded motor cable and Class C2 with max. 100 m cable.

## Footprint line filters, SK LF2 (IP20)

For frequency inverter powers of up to 37 kW (400 V) are available. The line filter can be mounted flat underneath the frequency inverter.

This reduces the space which is required. These line filters enable interference suppression Class C1 with max. 25 m shielded motor cable and Class C2 with max. 50 m cable.



## Footprint combined line filter

Inverter type SK 5xxE ...		Line filter type IP20	Part Number
3~ 230 V	0.25 ... 0.75 kW	SK NHD-480/6-F	278 273 006
	1.1 ... 2.2 kW	SK NHD-480/10-F	278 273 010
	3.0 ... 4.0 kW	SK NHD-480/16-F	278 273 016
3~ 400 V	0.55 ... 0.75 kW	SK NHD-480/3-F	278 273 003
	1.1 ... 2.2 kW	SK NHD-480/6-F	278 273 006
	3.0 ... 4.0 kW	SK NHD-480/10-F	278 273 010
	5.5 ... 7.5 kW	SK NHD-480/16-F	278 273 016

## Footprint line filter

Inverter type SK 5xxE ...		Line filter type IP00	Part Number
3~ 230 V	5.5 ... 7.5 kW	SK LF2-480/45-F	278 273 045
	11 kW	SK LF2-480/66-F	278 273 066
3~ 400 V	11 ... 15 kW	SK LF2-480/45-F	278 273 045
	18.5 ... 22 kW	SK LF2-480/66-F	278 273 066
	30 ... 37 kW	SK LF2-480/105-F	278 273 105

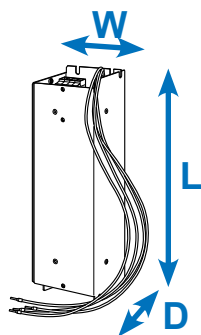

Footprint combined line filter

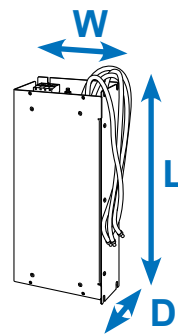

Footprint line filter

Continuous current [A]	Inductance [mH]	Leakage current <sup>1</sup> [mA]	L [mm]	W [mm]	D [mm]
5.5	3 x 6.4	1 / 10	290	88	74
9.5	3 x 3.7	12 / 120	305	115	98
16	3 x 2.2	12 / 120	350	140	98
2.3	3 x 15.3	1 / 10	250	75	60
5.5	3 x 6.4	1 / 10	290	88	74
9.5	3 x 3.7	12 / 120	305	115	98
16	3 x 2.2	12 / 120	350	140	98

Continuous current [A]	Leakage current <sup>1</sup> [mA]	L [mm]	W [mm]	D [mm]
45	12 / 120	388	164	75
66	12 / 120	428	182	75
45	12 / 120	388	164	75
66	12 / 120	428	182	75
105	22 / 210	527	210	95

<sup>1</sup> Leakage current 1st value: rated according to max. permissible fluctuation of input voltage according to IEC 38 + 10 %  
 Leakage current 2nd value: calculated with max. input voltage and failure of 2 phases (typically at 50 Hz)

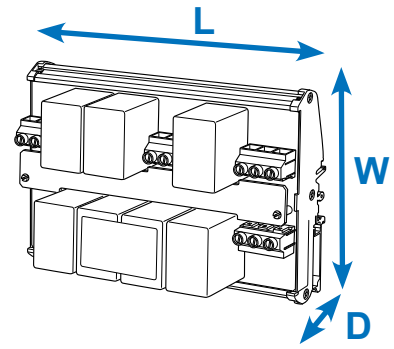

# Line filters

## Overvoltage filter, SK CIF (IP20)

In order to comply with the requirements of cUL (Canadian market) the use of a suitable overvoltage filter is mandatory.

In addition, for 230 V devices, operation of the frequency inverter with a suitable overvoltage filter is only permissible if a line choke is also used.

**Note:** For devices of Size 7 and above, no overvoltage filters are necessary in order to fulfil the requirements of cUL. The devices fulfil these requirements without further additions.

Inverter type SK 5xxE ...	Line filter type IP20	Part Number	Continuous current [A]	L <sup>1</sup> [mm]	W <sup>1</sup> [mm]	D <sup>1</sup> [mm]
3~ 230 V	0.25 ... 3.0 kW	SK CIF-323-20	20	180.5 / 204.5	126 / 126	76.5 / 62.5
	4.0 ... 11 kW	SK CIF-323-40	40	180.5 / 204.5	126 / 126	76.5 / 62.5
3~ 400 V	0.55 ... 7.5 kW	SK CIF-340-30	30	180.5 / 204.5	126 / 126	71 / 57
	11 ... 22 kW	SK CIF-340-60	60	180.5 / 204.5	126 / 126	71 / 57



<sup>1</sup> Dimensions, 1st value: Top hat rail fastening  
Dimensions, 2nd value: Wall-mounting

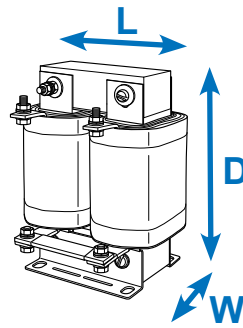

## Link circuit choke

### Link circuit choke SK DCL (IP00)

Reduces the line load of a frequency inverter due to its operating principle in a similar manner to a mains choke. It is connected into the link circuit of the frequency inverter at the easily accessible contacts which are provided and is available for 45 kW and above (IP00)

Inverter type SK 5xxE ...	Choke type IP00	Part Number	Continuous current [A]	Inductance [mH]	L x W x D [mm]
45 ... 55 kW	SK DCL-950/120-C	276 997 120	120	0.5	146 x 145 x 205
75 ... 90 kW	SK DCL-950/200-C	276 997 200	200	0.3	170 x 175 x 235
110 ... 160 kW	in preparation				



# Mains chokes

## General information

For some drive systems it may be necessary to use input chokes to reduce dangerous mains current peaks.

With their use, external mains feedback effects are considerably reduced and the proportion of current harmonics is reduced to a minimum. The input current is reduced to approximately the value of the output current.

It is recommended that a mains choke is always used for frequency inverters with a power of more than 45 kW. This also positively influences the device safety and EMC behaviour. All chokes have protection class IP00 and are UL certified.



## 1~ 230 V

Inverter type SK 5xxE ...	Choke type IP00	Part Number
0.25 ... 0.75 kW	SK CI1-230/8-C	278 999 030
1.1 ... 2.2 kW	SK CI1-230/20-C	278 999 040

## 3~ 230 V

Inverter type SK 5xxE ...	Choke type IP00	Part Number
0.25 ... 0.75 kW	SK CI1-480/6-C	276 993 006
1.1 ... 1.5 kW	SK CI1-480/11-C	276 993 011
2.2 ... 3.0 kW	SK CI1-480/20-C	276 993 020
4.0 ... 7.5 kW	SK CI1-480/40-C	276 993 040
11 ... 15 kW	SK CI1-480/70-C	276 993 070

## 3~ 400 V

Inverter type SK 5xxE ...	Choke type IP00	Part Number
0.55 ... 2.2 kW	SK CI1-480/6-C	276 993 006
3.0 ... 4.0 kW	SK CI1-480/11-C	276 993 011
5.5 ... 7.5 kW	SK CI1-480/20-C	276 993 020
11 ... 15 kW	SK CI1-480/40-C	276 993 040
18.5 ... 30 kW	SK CI1-480/70-C	276 993 070
37 ... 45 kW	SK CI1-480/100-C	276 993 100
55 ... 75 kW	SK CI1-480/160-C	276 993 160
90 kW	SK CI1-480/280-C	276 993 280
110 ... 132 kW	SK CI1-480/350-C	276 993 350
160 kW	not available	



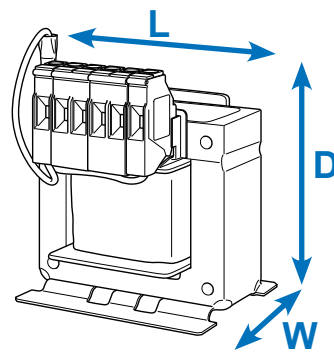

Continuous current [A]	Inductance [mH]	L [mm]	W [mm]	D [mm]
8	2 x 1.0	65	78	89
20	2 x 0.4	90	96	106

Continuous current [A]	Inductance [mH]	L [mm]	W [mm]	D [mm]
6	3 x 4.88	96	60	117
11	3 x 2.93	120	85	140
20	3 x 1.47	155	110	177
40	3 x 0.73	155	115	172
70	3 x 0.47	185	122	220

Continuous current [A]	Inductance [mH]	L [mm]	W [mm]	D [mm]
6	3 x 4.88	96	60	117
11	3 x 2.93	120	85	140
20	3 x 1.47	155	110	177
40	3 x 0.73	155	115	172
70	3 x 0.47	185	122	220
100	3 x 0.29	240	148	263
160	3 x 0.18	352	140	268
280	3 x 0.10	352	169	268
350	3 x 0.08	352	169	268

# Motor chokes

## General information

Long motor cable lengths (cable capacity) often require the use of additional motor chokes (output chokes) chokes on the frequency inverter output.

In addition, the protection of the device and the EMC characteristics are positively influenced by the use of motor chokes.

The motor chokes specified in the tables are rated for a pulse frequency of 3 to 6 kHz and an output frequency of 0 to 120 Hz. All chokes have protection class IP00 and are UL certified.

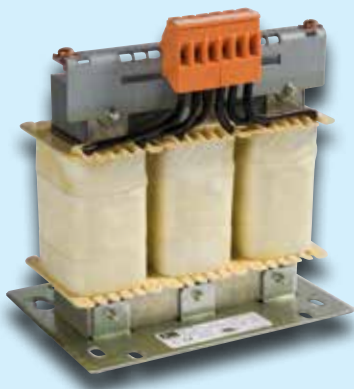

## 3~ 230 V

Inverter type SK 5xxE ...	Choke type IP00	Part Number
0.25 ... 0.75 kW	SK CO1-460/4-C	276 996 004
1.1 ... 1.5 kW	SK CO1-460/9-C	276 996 009
2.2 ... 4.0 kW	SK CO1-460/17-C	276 996 017
5.5 ... 7.5 kW	SK CO1-460/33-C	276 996 033
11 ... 15 kW	SK CO1-480/60-C	276 992 060

## 3~ 400 V

Inverter type SK 5xxE ...	Choke type IP00	Part Number
0.55 ... 1.5 kW	SK CO1-460/4-C	276 996 004
2.2 ... 3.0 kW	SK CO1-460/9-C	276 996 009
4.0 ... 7.5 kW	SK CO1-460/17-C	276 996 017
11 ... 15 kW	SK CO1-460/33-C	276 996 033
18.5 ... 30 kW	SK CO1-480/60-C	276 992 060
37 ... 45 kW	SK CO1-460/90-C	276 996 090
55 ... 75 kW	SK CO1-460/170-C	276 996 170
90 ... 110 kW	SK CO1-460/240-C	276 996 240
132 ... 160 kW	SK CO1-460/330-C	276 996 330

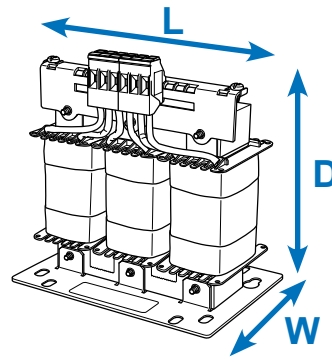

Continuous current [A]	Inductance [mH]	L [mm]	W [mm]	D [mm]
4	3 x 3.5	120	104	140
9	3 x 2.5	155	110	160
17	3 x 1.2	185	102	201
33	3 x 0.6	185	122	201
60	3 x 0.33	185	112	210

Continuous current [A]	Inductance [mH]	L [mm]	W [mm]	D [mm]
4	3 x 3.5	120	104	140
9	3 x 2.5	155	110	160
17	3 x 1.2	185	102	201
33	3 x 0.6	185	122	201
60	3 x 0.33	185	112	210
90	3 x 0.22	352	144	325
170	3 x 0.13	412	200	320
240	3 x 0.07	412	225	320
330	3 x 0.03	352	188	268

# Brake resistors

## Footprint resistors SK BR4 (IP40)

Four sizes for frequency inverter powers of up to 7.5 kW (400 V) are available. This braking resistor can be mounted flat or vertically, next to the frequency inverter. This reduces the space which is required. The specified resistance values are electrically matched to standard applications.



## Footprint resistors

Inverter type SK 5xxE ...		Resistor type IP40	Part Number
230 V / 115 V	0.25 ... 0.37 kW	SK BR4-240/100	275 991 110
	0.55 ... 0.75 kW	SK BR4-150/100	275 991 115
	1.1 ... 2.2 kW	SK BR4-75/200	275 991 120
	3.0 ... 4.0 kW	SK BR4-35/400	275 991 140
400 V	0.55 ... 0.75 kW	SK BR4-400/100	275 991 210
	1.1 ... 2.2 kW	SK BR4-220/200	275 991 220
	3.0 ... 4.0 kW	SK BR4-100/400	275 991 240
	5.5 ... 7.5 kW	SK BR4-60/600	275 991 260
	Temperature monitoring for BR4- resistors mounted close to the inverter		
Temperature monitoring for BR4- resistors mounted directly below the frequency inverter			275 991 200

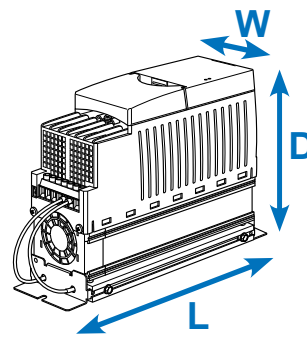

Resistance [Ω]	Continuous rating [W]	Energy consumption* [kWs]	L [mm]	W [mm]	D [mm]
240	100	1.0	230	88	175
150	100	1.0	230	88	175
75	200	3.0	270	88	175
35	400	6.0	285	98	239
400	100	1.0	230	88	175
220	200	3.0	270	88	175
100	400	7.0	285	98	239
60	600	12.0	330	98	239
Bimetal switch as opener			Wide brake resistor +10mm (one side) The dimensions apply to the frequency inverter, including the brake resistor		
Bimetal switch as opener					

\* max. 1.2 s once within 120 s

# Braking resistors

## Chassis - brake resistors, SK BR2 (IP20)

The resistor elements are integrated into a housing grating and must be connected to the particular frequency inverter via a separate connecting cable.

The brake resistors must be installed horizontally (except for SK BR2-xxx/400-C).

For this, a shielded cable should be used, which is as short as possible.



## Chassis resistors

Inverter type SK 5xxE ...		Resistor type IP20	Part Number
230 V	3.0 ... 4.0 kW	SK BR2-35/400-C <sup>1</sup>	278 282 045
	5.5 ... 7.5 kW	SK BR2-22/600-C	278 282 065
	11 kW	SK BR2-12/1500-C	278 282 015
	15 kW	SK BR2-9/2200-C	278 282 122
400 V	3.0 ... 4.0 kW	SK BR2-100/400-C <sup>1</sup>	278 282 040
	5.5 ... 7.5 kW	SK BR2-60/600-C	278 282 060
	11 ... 15 kW	SK BR2-30/1500-C	278 282 150
	18.5 ... 22 kW	SK BR2-22/2200-C	278 282 220
	30 ... 37 kW	SK BR2-12/4000-C	278 282 400
	45 ... 55 kW	SK BR2-8/6000-C	278 282 600
	75 ... 90 kW	SK BR2-6/7500-C	278 282 750
	110 ... 160 kW	SK BR2-3/7500-C	278 282 753
Temperature monitoring for BR2 resistors integrated (2 terminals 4 mm <sup>2</sup> )			

)<sup>1</sup> Vertical installation

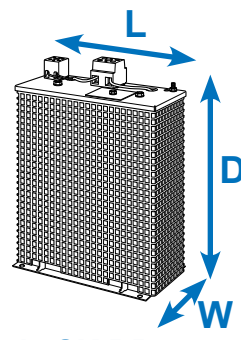
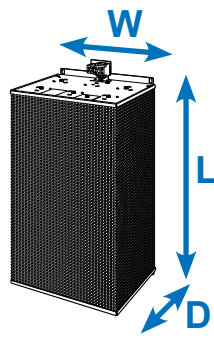

Only SK BR2-xxx/400-C

Resistance [Ω]	Continuous rating [W]	Energy consumption* [kWs]	L [mm]	W [mm]	D [mm]
35	400	6.0	178	100	252
22	600	7.5	385	92	120
12	1500	20.0	585	185	120
9	2200	28.0	485	275	120
100	400	6.0	178	100	252
60	600	7.5	385	110	120
30	1500	20.0	585	185	120
22	2200	28.0	485	275	120
12	4000	52.0	585	266	210
8	6000	78.0	395	490	260
6	7500	104.0	595	490	270
3	7500	110.0	595	490	270
Bimetal switch as opener					

\* max. 1.2 s once within 120 s

# SK 5xxE frequency inverters

## 1~ 110 ... 120 V and 1 / 3~ 200 ... 240 V



**Output frequency** 0.0 ... 400.0 Hz

**Pulse frequency** 3.0 ... 16.0 kHz

**Typical overload capacity** 150 % for 60 s,  
200 % for 3.5 s

**Efficiency of frequency inverter** > 95 %

**Ambient temperature** 0°C ... +40°C (S1-100 % ED),  
0°C ... +50°C (S3-70 % ED 10 min)

**Protection class** IP20

**Regulation and control** Sensorless current vector control (ISD), linear V/f characteristic

**Motor temperature monitoring** I<sup>2</sup>t-Motor (UL approval), PTC / Bi-metal switch (no UL approval)

Inverter type SK 5xxE ...	Mains voltage	Output voltage	Nominal motor power 230 V [kW]
-250-112-O	1~ 110 ... 120 V, +/- 10 %, 47 ... 63 Hz	3~ 0 - 2x mains voltage	0.25
-370-112-O			0.37
-550-112-O			0.55
-750-112-O			0.75
-111-112-O			1.1

Inverter type SK 5xxE ...	Mains voltage	Nominal motor power 230 V [kW]
-250-323-A	1 / 3~ 200 ... 240 V, +/- 10 %, 47 ... 63 Hz	0.25
-370-323-A		0.37
-550-323-A		0.55
-750-323-A		0.75
-111-323-A		1.1
-151-323-A		1.5
-221-323-A	3~ 200 ... 240 V, +/- 10 %, 47 ... 63Hz	2.2
-301-323-A		3.0
-401-323-A		4.0
-551-323-A		5.5
-751-323-A		7.5
-112-323-A		11
-152-323-A		15





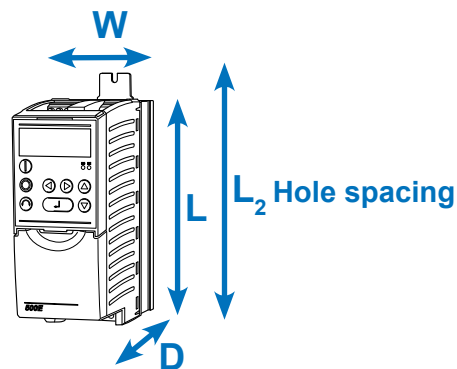

Nominal motor power 240 V [hp]	Nominal output current rms[A]	Typical input current rms[A]	Weight [kg]	Dimensions L (L <sub>2</sub> ) x W x D [mm]
1/3	1.7	8	1.4	Size 1: 186 (220) x 74 x 153
1/2	2.2	10	1.4	
3/4	3.0	13	1.4	
1	4.0	18	1.4	
1 1/2	5.3	23.5	1.4	

Nominal motor power 240 V [hp]	Nominal output current rms[A]	Typical input current rms[A]	Weight [kg]	Dimensions L (L <sub>2</sub> ) x W x D [mm]
1/3	1.7	3.7 / 2.4	1.4	Size 1: 186 (220) x 74 x 153
1/2	2.2	4.8 / 3.1	1.4	
3/4	3.0	6.5 / 4.2	1.4	
1	4.0	8.7 / 5.6	1.4	
1 1/2	5.5	12.0 / 7.7	1.8	Size 2: 226 (260) x 74 x 153
2	7.0	15.2 / 9.8	1.8	
3	9.5	19.6 / 13.3	1.8	
4	12.5	17.5	2.7	Size 3: 241 (275) x 98 x 181
5	16.0	22.4	2.7	
7 1/2	22	30.8	8.0	Size 5: 327 (357) x 162 x 224
10	28	39.2	8.0	
15	46	64.4	10.3	Size 6: 367 (397) x 180 x 234
20	60	84	15.0	Size 7: 456 (485) x 210 x 236



# SK 5xxE frequency inverters

## 3~ 380 ... 480 V

**Output frequency** 0.0 ... 400.0 Hz

**Pulse frequency** 3.0 ... 16.0 kHz

**Typical overload capacity** 150 % for 60 s,  
200 % for 3.5 s

**Efficiency of frequency inverter** > 95 %

**Ambient temperature** 0 ... +40°C  
(S1-100 % ED),  
0 ... +50°C  
(S3-70 % ED 10 min)

**Protection class** IP20

**Regulation and control** Sensorless current vector control (ISD), linear V/f characteristic

**Motor temperature monitoring** I<sup>2</sup>t-Motor (UL approval), PTC / Bi-metal switch (no UL approval)

Inverter type SK 5xxE ...	Mains voltage	Nominal motor power 400 V [kW]
-550-340-A	3~ 380 ... 480 V, -20 % / +10 %, 47 ... 63 Hz	0.55
-750-340-A		0.75
-111-340-A		1.1
-151-340-A		1.5
-221-340-A		2.2
-301-340-A		3.0
-401-340-A		4.0
-551-340-A		5.5
-751-340-A		7.5
-112-340-A		11.0
-152-340-A		15.0
-182-340-A		18.5
-222-340-A		22.0
-302-340-A		30.0
-372-340-A		37.0
-452-340-A		45.0
-552-340-A		55.0
-752-340-A	75.0	
-902-340-A	90.0	
-113-340-A	110.0	
-133-340-A	132.0	
-163-340-A*	160.0	

)\* in preparation

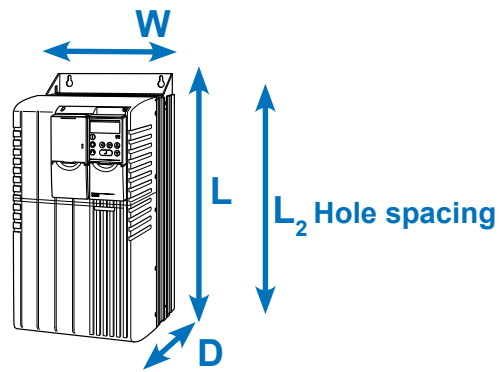

Nominal motor power 480 V [hp]	Nominal output current rms[A]	Typical input current rms[A]	Weight [kg]	Dimensions L (L <sub>2</sub> ) x W x D [mm]
3/4	1.7	2.4	1.4	Size 1: 186 (220) x 74 x 153
1	2.3	3.2	1.4	
1 1/2	3.1	4.3	1.8	Size 2: 226 (260) x 74 x 153
2	4.0	5.6	1.8	
3	5.5	7.7	1.8	
4	7.5	10.5	2.7	Size 3: 241 (275) x 98 x 181
5	9.5	13.3	2.7	
7 1/2	12.5	17.5	3.1	Size 4: 286 (320) x 98 x 181
10	16.0	22.4	3.1	
15	24.0	33.6	8.0	Size 5: 327 (357) x 162 x 224
20	31.0	43.4	8.0	
25	38.0	53.2	10.3	Size 6: 367 (397) x 180 x 234
30	46.0	64.4	10.3	
40	60.0	84.0	16.0	Size 7: 456 (485) x 210 x 236
50	75.0	105.0	16.0	
60	90.0	126.0	20.0	Size 8: 598 (582) x 265 x 286
75	110.0	154.0	20.0	
100	150.0	210.0	25.0	Size 9: 636 (620) x 265 x 286
125	180.0	252.0	25.0	
150	220.0	308.0	46.0	Size 10: 720 (704) x 395 x 292
180	260.0	364.0	49.0	
220	320.0	448.0	52.0	Size 11: 799 (783) x 395 x 292



**[www.nord.com/locator](http://www.nord.com/locator)**

**Headquarters:**

**Getriebebau NORD GmbH & Co. KG**

Getriebebau-Nord-Straße 1

22941 Bargteheide, Germany

Fon +49 (0) 4532 / 289-0

Fax +49 (0) 4532 / 289-2253

info@nord.com, www.nord.com

**Member of the NORD DRIVESYSTEMS GROUP**

